



## Auto Bilge Pumps

### Features & Benefits

- All-in-one pump & switch-No float switch required
- Pump turns on when water level rises & shuts off when water is removed
- Will not pump oil - straight motor oil that enters the bilge will not turn the pump on
- Snap-off strainer for easy cleaning
- Anti-fouling impeller
- Available in 600 & 750 GPH (2271 & 2838 LPH) models in 12 and 24 volt versions

### Typical Applications

Marine  
RV & Campers  
Industrial

### PUMP

**Liquid Temperature**  
110°F (43°C) Max.

**Priming Capabilities**  
Not needed flooded suction

**Power**  
3.0 amps max current draw

**Max Pressure**  
Not needed

**Outlet Ports**  
3/4" (19 mm) Hose Barb

### Weight

1.03 lbs (0.47 kg)

### Voltage

12v/24v

### MOTOR

**Type**  
Compact, efficient, long life motor

**Leads**  
18 AWG, 1 m long Leads

**Temperature Limits**  
110°F (43°C) Max.

**Duty Cycle**  
Intermittent

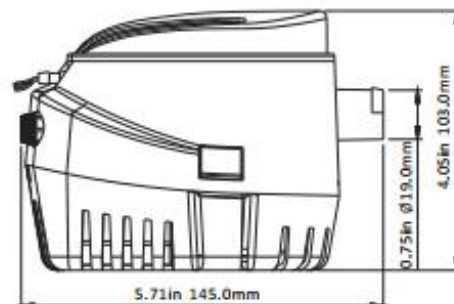
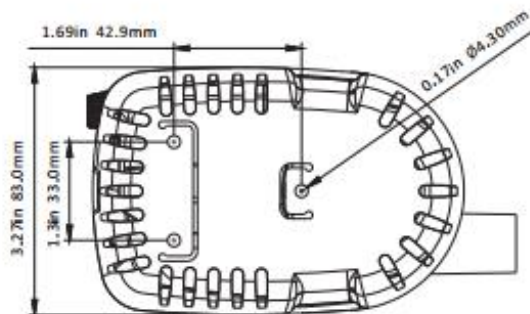

### STANDARD PUMP CONFIGURATIONS

Model	Flow rate	Volts	Current	Head	Wire lead	Outlet Dia	N.W/G.W
SFBP1-G600-06	600 GPH	12V	2.5A	2.5 m	1 m	19 mm/3/4"	0.47/0.52 kg
SFBP2-G600-06	600 GPH	24V	1.5A	2.5 m	1 m	19 mm/3/4"	0.47/0.52 kg
SFBP1-G750-06	750 GPH	12V	3.0A	3.0 m	1 m	19 mm/3/4"	0.47/0.52 kg
SFBP2-G750-06	750 GPH	24V	1.6A	3.0 m	1 m	19 mm/3/4"	0.47/0.52 kg